

EMC Test Report

Client Name : Acrel Co., Ltd.

Address : No.253, Yulv Road, Jiading District, Shanghai, China

Product Name : Multi channel energy meter

Date : Sept. 30, 2020

Shenzhen Anbotek Compliance Laboratory Limited



Contents

1. General Information.....	6
1.1. Client Information.....	6
1.2. Description of Device (EUT).....	6
1.3. Auxiliary Equipment Used During Test.....	6
1.4. Description of Test Mode.....	7
1.5. Test Summary.....	7
1.6. Test Equipment List.....	8
1.7. Description of Test Facility.....	10
1.8. EMS Performance Criteria.....	10
2. Power Line Conducted Emission Test.....	11
2.1. Test Standard and Limit.....	11
2.2. Test Setup.....	11
2.3. EUT Configuration on Measurement.....	11
2.4. Operating Condition of EUT.....	11
2.5. Test Procedure.....	12
2.6. Test Results.....	12
3. Radiated Emission Test.....	15
3.1. Test Standard and Limit.....	15
3.2. Test Setup.....	15
3.3. EUT Configuration on Measurement.....	15
3.4. Operating Condition of EUT.....	16
3.5. Test Procedure.....	16
3.6. Test Results.....	16
4. Harmonic Current Emission Test.....	19
4.1. Test Standard.....	19
4.2. Test Setup.....	19
4.3. Operating Condition of EUT.....	19
4.4. Test Results.....	19
5. Voltage Fluctuations & Flicker Test.....	20
5.1. Test Standard.....	20
5.2. Test Setup.....	20
5.3. Operating Condition of EUT.....	20
5.4. Test Results.....	20
6. Electrostatic Discharge Immunity Test.....	22
6.1. Test Standard and Level.....	22
6.2. Test Setup.....	22
6.3. EUT Configuration on Measurement.....	22
6.4. Operating Condition of EUT.....	22
6.5. Test Procedure.....	23
6.6. Test Results.....	23



7. RF Field Strength Susceptibility Test.....	25
7.1. Test Standard and Level.....	25
7.2. Test Setup.....	25
7.3. EUT Configuration on Measurement.....	26
7.4. Operating Condition of EUT.....	26
7.5. Test Procedure.....	26
7.6. Measuring Results.....	26
8. Electrical Fast Transient/Burst Immunity Test.....	28
8.1. Test Standard and Level.....	28
8.2. Test Setup.....	28
8.3. EUT Configuration on Measurement.....	28
8.4. Operating Condition of EUT.....	28
8.5. Test Procedure.....	29
8.6. Test Results.....	29
9. Surge Immunity Test.....	31
9.1. Test Standard and Level.....	31
9.2. Test Setup.....	31
9.3. EUT Configuration on Measurement.....	31
9.4. Operating Condition of EUT.....	31
9.5. Test Procedure.....	32
9.6. Test Results.....	32
10. Injected Currents Susceptibility Test.....	34
10.1. Test Standard and Level.....	34
10.2. Test Setup.....	34
10.3. EUT Configuration.....	34
10.4. Operating Condition of EUT.....	34
10.5. Test Procedure.....	35
10.6. Test Results.....	35
11. MAGNETIC FIELD SUSCEPTIBILITY TEST.....	37
11.1. Test Standard and Level.....	37
11.2. Test Setup.....	37
11.3. EUT Configuration on Test.....	37
11.4. Operating Condition of EUT.....	37
11.5. Test Procedure.....	38
11.6. Test Results.....	38
12. Voltage Dips And Interruptions Test.....	40
12.1. Test Standard and Level.....	40
12.2. Test Setup.....	40
12.3. EUT Configuration on Measurement.....	40
12.4. Operating Condition of EUT.....	40
12.5. Test Procedure.....	41
12.6. Test Results.....	41
APPENDIX I -- TEST SETUP PHOTOGRAPH.....	43



TEST REPORT

Applicant : Acrel Co., Ltd.
Manufacturer : Jiangsu Acrel Electrical Manufacturing. Co., Ltd.
Product Name : Multi channel energy meter
Model No. : AMC16MA, AMC16, AMC16MAH, AMC16Z, AMC16ZH, AMC16MD
Trade Mark : Acrel
Rating(s) : AC 85-270V, 20mA
DC 48V
Test Standard(s) : **EN 61326-1: 2013;**
EN IEC 61000-3-2: 2019;
EN 61000-3-3: 2013+A1:2019;
(IEC 61000-4-2; IEC 61000-4-3; IEC 61000-4-4;
IEC 61000-4-5; IEC 61000-4-6; IEC 61000-4-8; IEC 61000-4-11)

The device described above is tested by Shenzhen Anbotek Compliance Laboratory Limited to determine the maximum emission levels emanating from the device and the severe levels of the device can endure and its performance criterion. The measurement results are contained in this test report and Shenzhen Anbotek Compliance Laboratory Limited is assumed full responsibility for the accuracy and completeness of these measurements. Also, this report shows that the EUT to be technically compliant with the EN 61326-1, EN IEC 61000-3-2, EN 61000-3-3 requirements.

This report applies to above tested sample only and shall not be reproduced in part without written approval of Shenzhen Anbotek Compliance Laboratory Limited.

Date of Receipt: Sept. 18, 2020

Date of Test: Sept 21~24, 2020

Prepared By: Winnie Huang
(Engineer / Winnie Huang)

Reviewer: Well Wang
(Supervisor / Well Wang)

Approved & Authorized Signer: KingKong Jin
(Manager / KingKong Jin)

1. General Information

1.1. Client Information

Applicant	:	Acrel Co., Ltd.
Address	:	No.253, Yulv Road, Jiading District, Shanghai, China
Manufacturer	:	Jiangsu Acrel Electrical Manufacturing. Co., Ltd.
Address	:	No.5, Dongmeng Road, Nanzha Street, Jiangyin City, Jiangsu Province, China
Factory	:	Jiangsu Acrel Electrical Manufacturing. Co., Ltd.
Address	:	No.5, Dongmeng Road, Nanzha Street, Jiangyin City, Jiangsu Province, China

1.2. Description of Device (EUT)

Product Name	:	Multi channel energy meter
Model No.	:	AMC16MA, AMC16, AMC16MAH, AMC16Z, AMC16ZH, AMC16MD (Note: All samples are the same except the model number & appearance, so we prepare "AMC16MA" for test only.)
Trade Mark	:	Acrel
Test Power Supply	:	AC 230V, 50Hz
Test Sample No.	:	1-1-1
Product Description	:	Adapter: N/A
Remark: (1) For a more detailed features description, please refer to the manufacturer's specifications or the User's Manual.		

1.3. Auxiliary Equipment Used During Test

N/A	
-----	--



1.4. Description of Test Mode

Pretest Mode	Description
Mode 1	On

For Mode 1 Block Diagram of Test Setup

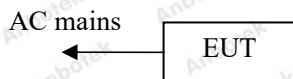

1.5. Test Summary

Test Items	Test Mode	Status
Power Line Conducted Emission Test (150KHz To 30MHz)	Mode 1	P
Radiated Emission Test (30MHz To 1000MHz)	Mode 1	P
Harmonic Current Test	/	N
Voltage Fluctuations and Flicker Test	Mode 1	P
Electrostatic Discharge immunity Test	Mode 1	P
RF Field Strength susceptibility Test	Mode 1	P
Electrical Fast Transient/Burst Immunity Test	Mode 1	P
Surge Immunity Test	Mode 1	P
Injected Currents Susceptibility Test	Mode 1	P
Magnetic Field Susceptibility Test	Mode 1	P
Voltage Dips and Interruptions Test	Mode 1	P

P) Indicates "PASS".

N) Indicates "Not applicable".

1.6. Test Equipment List

Conducted Emission Measurement

Item	Equipment	Manufacturer	Model No.	Serial No.	Last Cal.	Cal. Interval
1.	L.I.S.N. Artificial Mains Network	Rohde & Schwarz	ENV216	100055	Nov. 04, 2019	1 Year
2.	L.I.S.N. Artificial Mains Network	Schwarzbeck	NSLK 8127	8127386	Nov. 04, 2019	1 Year
3.	EMI Test Receiver	Rohde & Schwarz	ESCI	100627	Nov. 04, 2019	1 Year
4.	RF Switching Unit	Compliance Direction	RSU-M2	38303	Nov. 04, 2019	1 Year
5.	Software Name EZ-EMC	Ferrari Technology	ANB-03A	N/A	N/A	N/A

Radiated Emission Measurement

Item	Equipment	Manufacturer	Model No.	Serial No.	Last Cal.	Cal. Interval
1.	EMI Test Receiver	Rohde & Schwarz	ESCI	100627	Nov. 04, 2019	1 Year
2.	Pre-amplifier	Schwarzbeck	BBV-9745	9745-075	Nov. 04, 2019	1 Year
3.	Bilog Broadband Antenna	SCHWARZBECK	VULB 9163	01109	Nov. 01, 2019	1 Year
4.	Software Name EZ-EMC	Ferrari Technology	EMEC-3A1	N/A	N/A	N/A

Harmonic and Flicker Measurement

Item	Equipment	Manufacturer	Model No.	Serial No.	Last Cal.	Cal. Interval
1.	Programmable AC Power source	IVYTECH	APS-5005A	632734	Nov. 04, 2019	1 Year
2.	Harmonic and Flicker Analyzer	EMC-PARTNER	HMONICS 1000-1P	164	Nov. 04, 2019	1 Year
3.	Harmonics-1000	N/A	Ed.3.0+4.0	N.A	N/A	N/A

Electrostatic Discharge Measurement

Item	Equipment	Manufacturer	Model No.	Serial No.	Last Cal.	Cal. Interval
1.	ESD Simulators	emtest	ESD NX30.1	11891	Mar. 07, 2020	1 Year

Electrical Fast Transient/Burst Immunity Measurement

Item	Equipment	Manufacturer	Model No.	Serial No.	Last Cal.	Cal. Interval
1.1	EFT Burst Simulator	PRIMA	EFT61004B	PR10114282	Nov. 04, 2019	1 Year
1.2	EFT-Clamp	PRIMA	EFT-Clamp	/	Nov. 04, 2019	1 Year
2.1	EFT Burst Simulator	TESEQ	NSG 3060	1480	Nov. 04, 2019	1 Year
2.2	CDN	TESEQ	CDN 3061	1408	Nov. 04, 2019	1 Year

R/S Immunity Measurement

Item	Equipment	Manufacturer	Model No.	Serial No.	Last Cal.	Cal. Interval
1.	Signal Generator	Agilent	N5182A	MY48180656	Nov. 04, 2019	1 Year
2.	Amplifier	Micotoop	MPA-80-1000-250	MPA1903096	Nov. 04, 2019	1 Year
3.	Amplifier	Micotoop	MPA-1000-6000-100	MPA1903122	Nov. 04, 2019	1 Year
4.	Log-Periodic Antenna	Schwarzbeck	VULP9118E	00992	Apr. 17, 2020	1 Year
5.	Horn Antenna	Instruments corporation	GTH-0118	351600	Nov. 01, 2019	1 Year
6.	Power Sensor	Agilent	E9301A	MY41498906	Nov. 04, 2019	1 Year
7.	Power Sensor	Agilent	E9301A	MY41498088	Nov. 04, 2019	1 Year
8.	Power Meter	Agilent	E4419B	GB40202909	Nov. 04, 2019	1 Year
9.	Field Probe	ETS-Lindgren	HI-6006	00212747	Apr. 17, 2020	1 Year
10.	software	EMtrace	EM 3	N/A	N/A	N/A

Surge Measurement

Item	Equipment	Manufacturer	Model No.	Serial No.	Last Cal.	Cal. Interval
1.	Surge Generator	TESEQ	NSG 3060	1480	Nov. 04, 2019	1 Year
2.	CDN	TESEQ	CDN 3061	1408	Nov. 04, 2019	1 Year
3.	Telecom port surge generator	PMI	TW101	190411	Apr. 17, 2020	1 Year

Injected Currents Susceptibility Measurement

Item	Equipment	Manufacturer	Model No.	Serial No.	Last Cal.	Cal. Interval
1.	C/S Conducted Immunity Test System	FRANKONIA	CIT-10	126A1196/2012	Nov. 04, 2019	1 Year
2.	CDN	FRANKONIA	CDN - M2+ M3	A2210178/2012	Nov. 04, 2019	1 Year
3.	6dB Attenuator	FRANKONIA	DAM 26W	1172202	Nov. 04, 2019	1 Year
4.	CIT-10	FRANKONIA	Version1.1.7	N/A	N.A	N/A
5.	EM-Clamp	FRANKONIA	EMCL-20	18101728-0103	May 17, 2020	1 Year

Magnetic Field Susceptibility Measurement

Item	Equipment	Manufacturer	Model No.	Serial No.	Last Cal.	Cal. Interval
1.	Power Frequency Magnetic Field Generator	EVERFINE	EMS61000-8K	906002	Nov. 04, 2019	1 Year

Voltage Dips and Interruptions Measurement

Item	Equipment	Manufacturer	Model No.	Serial No.	Last Cal.	Cal. Interval
1.	CYCLE SAG Simulator	PRIMA	DRP61011AG	PR12046234	Nov. 04, 2019	1 Year

1.7. Description of Test Facility

The test facility is recognized, certified, or accredited by the following organizations:

FCC-Registration No.: 184111

Shenzhen Anbotek Compliance Laboratory Limited, EMC Laboratory has been registered and fully described in a report filed with the (FCC) Federal Communications Commission. The acceptance letter from the FCC is maintained in our files. Registration No. 184111, September 27, 2019.

ISED-Registration No.: 8058A

Shenzhen Anbotek Compliance Laboratory Limited, EMC Laboratory has been registered and fully described in a report filed with the (ISED) Innovation, Science and Economic Development Canada. The acceptance letter from the ISED is maintained in our files. Registration 8058A, March 07, 2019.

Test Location

Shenzhen Anbotek Compliance Laboratory Limited.
1/F, Building D, Sogood Science and Technology Park, Sanwei community, Hangcheng Street, Bao'an District, Shenzhen, Guangdong, China.518128

1.8. EMS Performance Criteria

- √ A: Normal performance within the specification limits
- √ B: Temporary degradation or loss of function or performance which is self-recoverable
- √ C: Temporary degradation or loss of function or performance which requires operator intervention or system reset
- √ D: Degradation or loss of function which is not recoverable due to damage of equipment (components) or software, or loss of data

Note: The manufacturer's specification may define effects on the EUT which may be considered insignificant, and therefore acceptable.

This classification may be used as a guide in formulating performance criteria, by committees responsible for generic, product and product-family standards, or as a framework for the agreement on performance criteria between the manufacturer and the purchaser, for example where no suitable generic, product or product-family standard exists.

2. Power Line Conducted Emission Test

2.1. Test Standard and Limit

Test Standard	EN 61326-1
---------------	------------

Limits for conducted emissions

Test Limit	Frequency ((MHz))	At mains terminals (dB μ V)	
		Quasi-peak Level	Average Level
	0.15 ~ 0.50	79	66
	0.50 ~ 30.00	73	60

Remark: (1) The lower limit shall apply at the transition frequencies.

(2) The limit decreases linearly with the logarithm of the frequency in the range 0.15MHz to 0.50MHz.

2.2. Test Setup

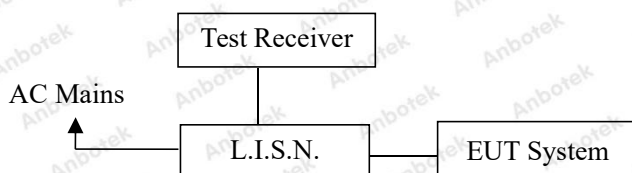

2.3. EUT Configuration on Measurement

The following equipments are installed on Conducted Emission Measurement to meet EN 61326-1 requirements and operating in a manner which tends to maximize its emission characteristics in a normal application.

2.4. Operating Condition of EUT

2.4.1. Setup the EUT as shown in Section 2.2.

2.4.2. Turn on the power of all equipments.

2.4.3. Let the EUT work in test mode and measure it.

2.5. Test Procedure

The EUT is put on the table which is 0.8 meter high above the ground and connected to the AC mains through a Line Impedance Stabilization Network (L.I.S.N.). This provided a 50ohm coupling impedance for the tested equipments. Both sides of AC line are checked to find out the maximum conducted emission according to the EN 61326-1 regulations during conducted emission measurement. And the voltage probe had been used for the load terminals measurement according to the EN 61326-1 standard.

The bandwidth of the test receiver (ESCI) is set at 9KHz in 150KHz~30MHz.

The frequency range from 150KHz to 30MHz is investigated for AC mains.

All the test results are listed in Section 2.6.

2.6. Test Results

PASS

The test curves are shown in the following pages.



Conducted Emission Test Data

Test Site: 1# Shielded Room
 Test Specification: AC 230V, 50Hz
 Comment: Live Line
 Temp.: 25.2°C Hum.: 51%

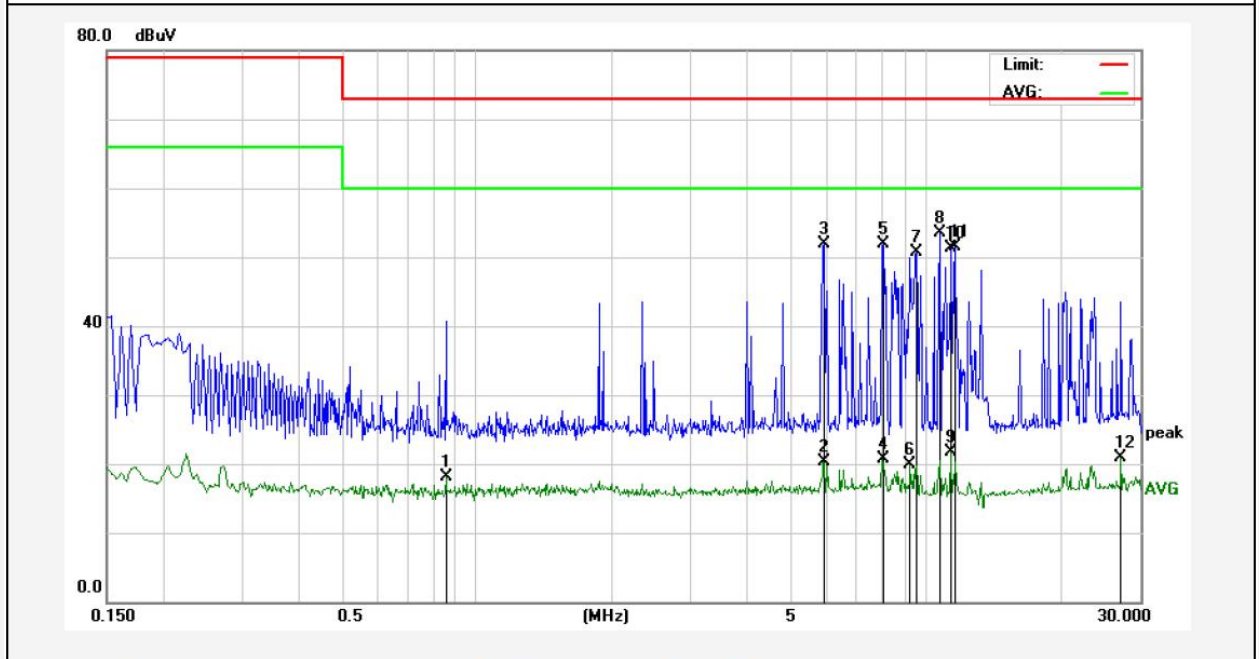

No.	Freq. (MHz)	Reading (dBuV)	Factor (dB)	Result (dBuV)	Limit dBuV	Over Limit (dB)	Detector	Remark
1	0.8540	-1.88	20.08	18.20	60.00	-41.80	AVG	
2	5.9220	0.06	20.23	20.29	60.00	-39.71	AVG	
3	5.9380	31.60	20.23	51.83	73.00	-21.17	QP	
4	8.0020	0.45	20.29	20.74	60.00	-39.26	AVG	
5	8.0580	31.56	20.29	51.85	73.00	-21.15	QP	
6	9.2140	-0.39	20.32	19.93	60.00	-40.07	AVG	
7	9.5100	30.36	20.33	50.69	73.00	-22.31	QP	
8	10.7340	33.11	20.33	53.44	73.00	-19.56	QP	
9	11.3540	1.29	20.32	21.61	60.00	-38.39	AVG	
10	11.3820	30.93	20.32	51.25	73.00	-21.75	QP	
11	11.5659	31.10	20.31	51.41	73.00	-21.59	QP	
12	27.1860	0.68	20.28	20.96	60.00	-39.04	AVG	

Note: Result=Reading+Factor Over Limit=Result-Limit

Conducted Emission Test Data

Test Site: 1# Shielded Room
 Test Specification: AC 230V, 50Hz
 Comment: Neutral Line
 Temp.: 25.2°C Hum.: 51%

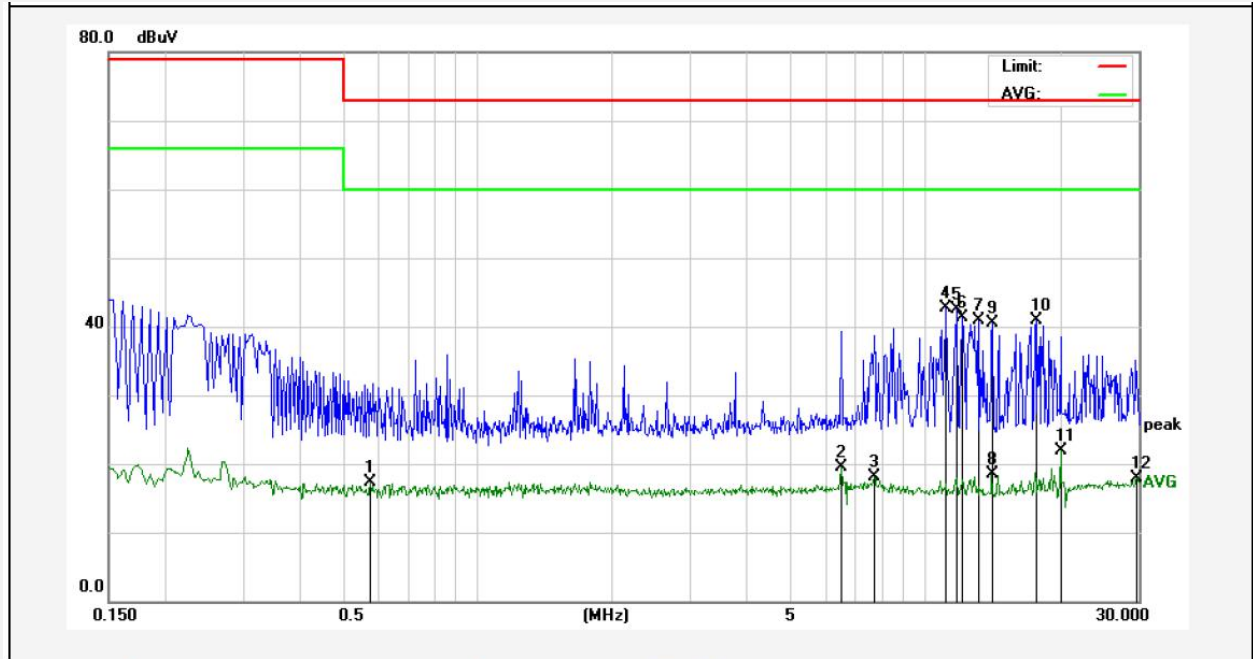

No.	Freq. (MHz)	Reading (dBuV)	Factor (dB)	Result (dBuV)	Limit dBuV	Over Limit (dB)	Detector	Remark
1	0.5780	-2.61	20.00	17.39	60.00	-42.61	AVG	
2	6.5060	-0.78	20.25	19.47	60.00	-40.53	AVG	
3	7.7140	-2.19	20.28	18.09	60.00	-41.91	AVG	
4	11.1740	22.31	20.32	42.63	73.00	-30.37	QP	
5	11.7620	22.19	20.31	42.50	73.00	-30.50	QP	
6	12.1580	21.07	20.31	41.38	73.00	-31.62	QP	
7	13.2620	20.70	20.29	40.99	73.00	-32.01	QP	
8	14.1100	-1.83	20.27	18.44	60.00	-41.56	AVG	
9	14.1940	20.26	20.27	40.53	73.00	-32.47	QP	
10	17.6940	20.62	20.30	40.92	73.00	-32.08	QP	
11	20.0900	1.52	20.34	21.86	60.00	-38.14	AVG	
12	29.8140	-2.32	20.27	17.95	60.00	-42.05	AVG	

Note: Result=Reading+Factor Over Limit=Result-Limit

3. Radiated Emission Test

3.1. Test Standard and Limit

Test Standard	EN 61326-1
---------------	------------

Radiated Emission Test Limit

Test Limit	Frequency (MHz)	DISTANCE (Meters)	FIELD STRENGTHS LIMIT (dB μ V/m)
	30 ~ 230	3	50
	230 ~ 1000	3	57

Remark: (1) The smaller limit shall apply at the combination point between two frequency bands.
 (2) Distance refers to the distance in meters between the measuring instrument antenna and the closed point of any part of the EUT.

3.2. Test Setup

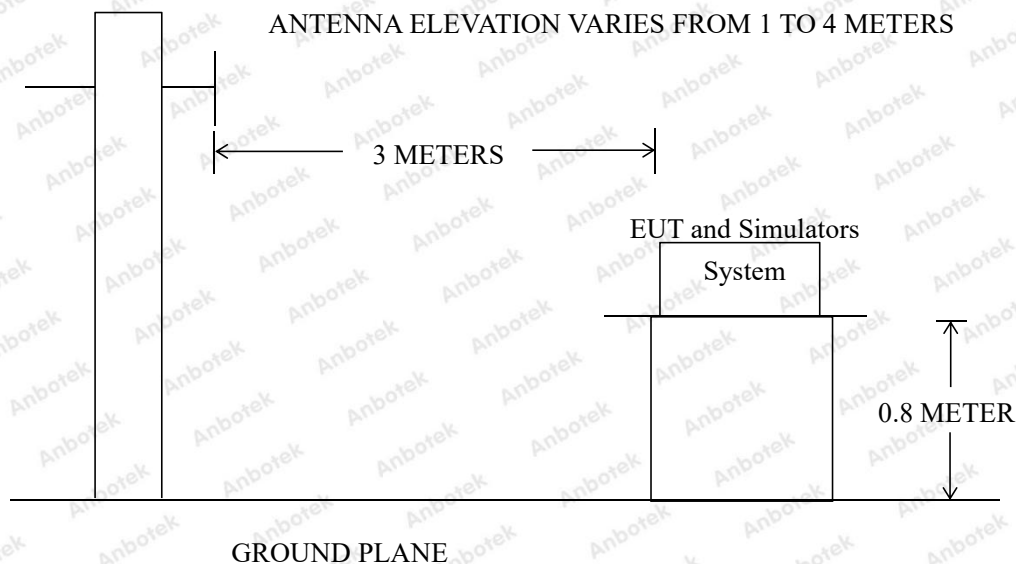

3.3. EUT Configuration on Measurement

The EN 61326-1 regulations test method must be used to find the maximum emission during radiated emission measurement.

3.4. Operating Condition of EUT

3.4.1. Setup the EUT as shown in Section 3.2.

3.4.2. Turn on the power of all equipments.

3.4.3. Let the EUT work in test mode and measure it.

3.5. Test Procedure

The EUT is placed on a turn table which is 0.8 meter high above the ground. The turn table can rotate 360 degrees to determine the position of the maximum emission level. The EUT is set 3 meters away from the receiving antenna which is mounted on an antenna tower. The antenna can be moved up and down from 1 to 4 meters to find out the maximum emission level. Bilog antenna is used as a receiving antenna. Both horizontal and vertical polarization of the antenna are set on test.

The bandwidth of the Receiver (ESCI) is set at 120kHz.

The EUT is tested in Chamber.

The test results are listed in Section 3.6.

3.6. Test Results

PASS

The frequency range from 30MHz to 1000MHz is investigated.

The test curves are shown in the following pages.



Test item: Radiation Test **Polarization:** Horizontal
Standard: (RE)EN61326-1_Class A **Power Source:** AC 230V, 50Hz
Distance: 3m **Temp.(°C)/Hum.(%RH):** 24.5(°C)/62%RH

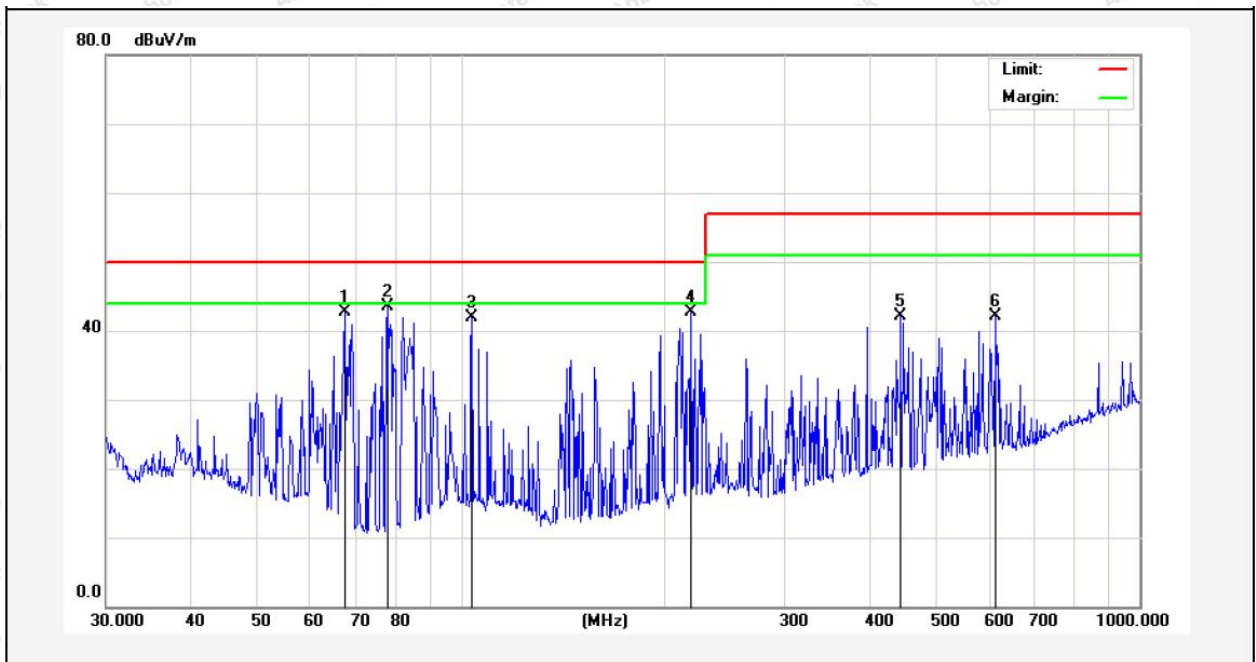

No.	Freq. (MHz)	Reading (dBuV/m)	Factor (dB/m)	Result (dBuV/m)	Limit (dBuV/)	Over Limit (dB)	Detector	Height (cm)	degree (deg)	Remark
1	67.4381	61.29	-18.51	42.78	50.00	-7.22	peak			
2	78.1389	64.93	-21.46	43.47	50.00	-6.53	peak			
3	103.8054	62.63	-20.71	41.92	50.00	-8.08	peak			
4	218.3085	62.88	-20.17	42.71	50.00	-7.29	peak			
5	444.8514	54.22	-12.18	42.04	57.00	-14.96	peak			
6	612.0642	53.04	-10.91	42.13	57.00	-14.87	peak			

Note: **Result=Reading+Factor** **Over Limit=Result-Limit**

Test item: Radiation Test **Polarization:** Vertical
Standard: (RE)EN61326-1_Class A **Power Source:** AC 230V, 50Hz
Distance: 3m **Temp.(°C)/Hum.(%RH):** 24.5(°C)/62%RH

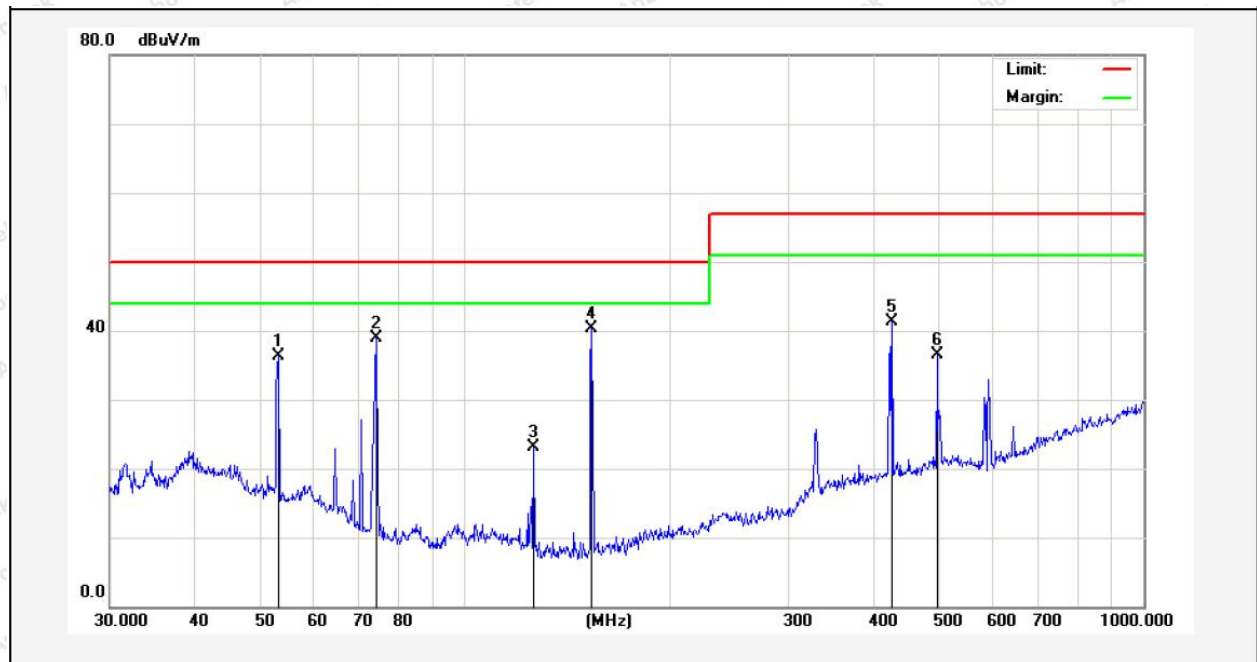

No.	Freq. (MHz)	Reading (dBuV/m)	Factor (dB/m)	Result (dBuV/m)	Limit (dBuV/)	Over Limit (dB)	Detector	Height (cm)	degree (deg)	Remark
1	53.1313	51.19	-14.79	36.40	50.00	-13.60	peak			
2	74.1351	59.39	-20.42	38.97	50.00	-11.03	peak			
3	126.3286	40.38	-17.27	23.11	50.00	-26.89	peak			
4	153.7385	58.40	-18.17	40.23	50.00	-9.77	peak			
5	426.5210	52.49	-11.25	41.24	57.00	-15.76	peak			
6	495.9344	47.54	-11.06	36.48	57.00	-20.52	peak			

Note: **Result=Reading+Factor** **Over Limit=Result-Limit**

4. Harmonic Current Emission Test

4.1. Test Standard

Test Standard	EN IEC 61000-3-2
---------------	------------------

4.2. Test Setup

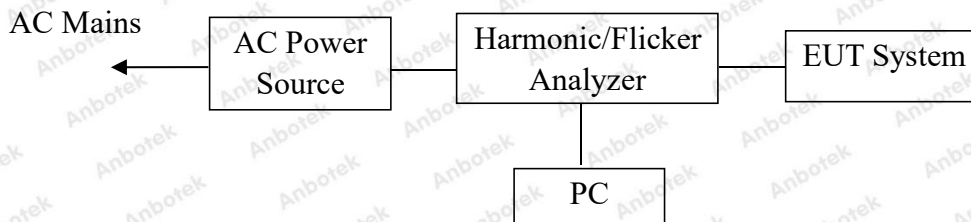

4.3. Operating Condition of EUT

- 4.3.1. Setup the EUT as shown on Section 4.2.
- 4.3.2. Turn on the power of all equipments.
- 4.3.3. After that, let the EUT work in test mode measure it.

4.4. Test Results

The active input power of the EUT is less than 75W. Therefore, according to EN IEC 61000-3-2, no limits are necessary.

5. Voltage Fluctuations & Flicker Test

5.1. Test Standard

Test Standard	EN 61000-3-3
---------------	--------------

5.2. Test Setup

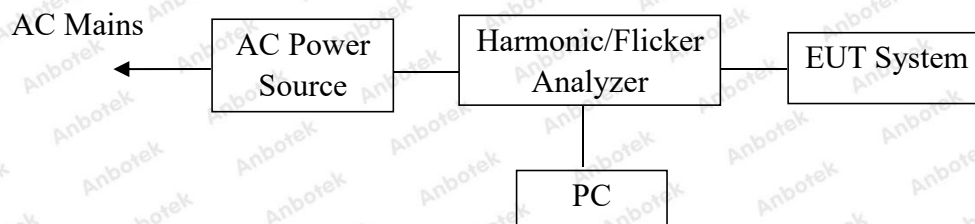

5.3. Operating Condition of EUT

5.3.1. Setup the EUT as shown on Section 5.2.

5.3.2. Turn on the power of all equipments.

5.3.3. After that, let the EUT work in test mode measure it.

5.4. Test Results

PASS

The test curves are shown in the following pages.

Flicker Test Summary per EN/IEC61000-3-3 (Run time)

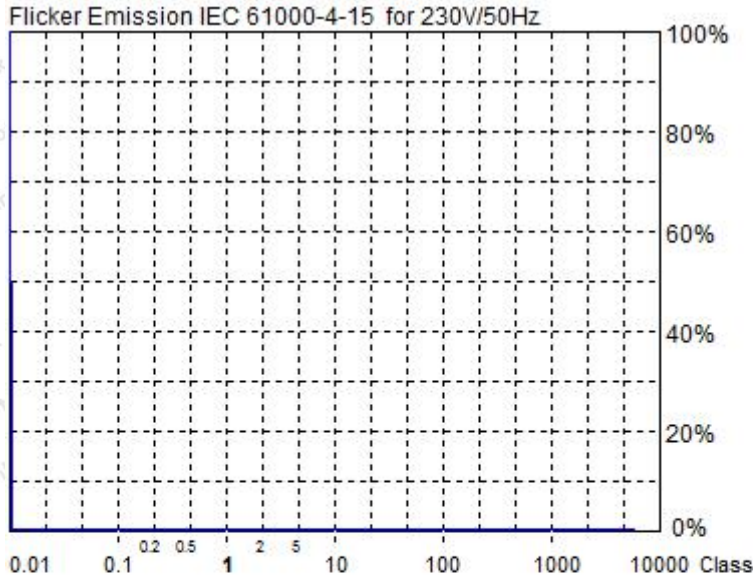

Actual Flicker (Fli):	0.00
Short-term Flicker (Pst):	0.07
Limit (Pst):	1.00
Long-term Flicker (Plt):	0.00
Limit (Plt):	0.65
Maximum Relative Volt. Change (dmax):	0.00%
Limit (dmax):	4.00%
Relative Steady-state Voltage Change (dc):	0.00%
Limit (dc):	3.00%
Tmax 3.00% (dt):	0.00ms
Limit (dt>Lim):	200ms

Flicker Emission - IEC 61000-3-3 , EN 61000-3-3

Urms = 229.5 V P = 1.522 W
 Irms = 0.014 A pf = 0.476

Range: 0.25 A
 V-nom: 230 V

Test aborted, Result: PASSED

HAR-1000 EMC-Partner

Full Bar : Actual Values
 Empty Bar : Maximum Values
 Circles : Average Values
 Blue : Current , Green : Voltage , Red : Failed
 Urms = 229.5V Freq = 50.000 Range: 0.25 A
 Irms = 0.014A Ipk = 0.056A cf = 4.000
 P = 1.522W S = 3.194VA pf = 0.476

Test - Time : 10 x 1min = 10min (100 %)

LIN (Line Impedance Network) : L: 0.24ohm +j0.15ohm N: 0.16ohm +j0.10ohm

Limits : Plt : 0.65 Pst : 1.00
 dmax : 4.00 % dc : 3.00 %
 dtLim: 3.00 % dt>Lim: 200ms

Test aborted, Result: PASSED

	dmax [%]	dc [%]	dt>Lim [ms]
1	0.000	0.000	0.000

6. Electrostatic Discharge Immunity Test

6.1. Test Standard and Level

Test Standard:	EN 61326-1 (IEC 61000-4-2)
Performance Criterion:	B
Severity Level: 3 / Air Discharge: ± 8 kV, Level: 2 / Contact Discharge: ± 4 kV	

Test Level

Level	Test Voltage Contact Discharge (kV)	Test Voltage Air Discharge (kV)
1.	± 2	± 2
2.	± 4	± 4
3.	± 6	± 8
4.	± 8	± 15
X.	Special	Special

6.2. Test Setup

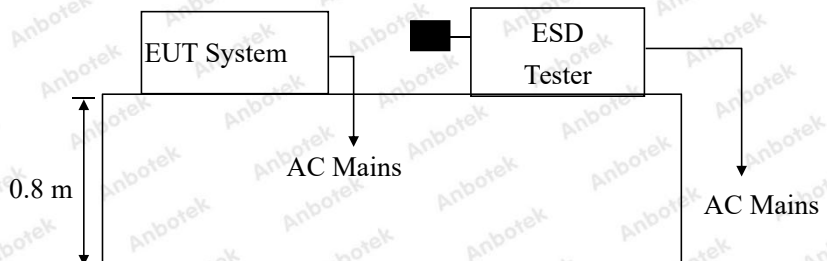

6.3. EUT Configuration on Measurement

The following equipments are installed on Electrostatic Discharge immunity Measurement to meet EN 61326-1 requirements and operating in a manner which tends to maximize its emission characteristics in a normal application.

6.4. Operating Condition of EUT

- 6.4.1. Setup the EUT as shown on Section 6.2.
- 6.4.2. Turn on the power of all equipments.
- 6.4.3. After that, let the EUT work in test mode measure it.

6.5. Test Procedure

6.5.1. Air Discharge:

This test is done on a non-conductive surface. The round discharge tip of the discharge electrode shall be approached as fast as possible to touch the EUT. After each discharge, the discharge electrode shall be removed from the EUT. The generator is then re-triggered for a new single discharge and repeated 10 times for each pre-selected test point. This procedure shall be repeated until all the air discharge completed.

6.5.2. Contact Discharge:

All the procedure shall be same as Section 6.5.1. except that the tip of the discharge electrode shall touch the EUT before the discharge switch is operated.

6.5.3. Indirect discharge for horizontal coupling plane

At least 20 single discharges shall be applied to the horizontal coupling plane, at points on each side of the EUT. The discharge electrode positions vertically at a distance of 0.1m from the EUT and with the discharge electrode touching the coupling plane.

6.5.4. Indirect discharge for vertical coupling plane

At least 20 single discharge shall be applied to the center of one vertical edge of the coupling plane. The coupling plane, of dimensions 0.5m × 0.5m, is placed parallel to, and positioned at a distance of 0.1m from the EUT. Discharges shall be applied to the coupling plane, with this plane in sufficient different positions that the four faces of the EUT are completely illuminated.

6.6. Test Results

PASS

Please refer to the following page.

Electrostatic Discharge Test Results

Air discharge :	±8.0kV	Temperature :	23.1℃
Contact discharge :	±4.0kV	Humidity :	50%
Power Supply :	AC 230V, 50Hz	Expert conclusion :	A
Test Result :	<input checked="" type="checkbox"/> Pass <input type="checkbox"/> Fail		

For each point positive 10 times and negative 10 times discharge

Location		Kind A-Air Discharge C-Contact Discharge	Result
Screw	4 points	C	<input checked="" type="checkbox"/> A <input type="checkbox"/> B <input type="checkbox"/> C <input type="checkbox"/> D
Slot	8 points	A	<input checked="" type="checkbox"/> A <input type="checkbox"/> B <input type="checkbox"/> C <input type="checkbox"/> D
HCP	4 points	C	<input checked="" type="checkbox"/> A <input type="checkbox"/> B <input type="checkbox"/> C <input type="checkbox"/> D
VCP of the front	4 points	C	<input checked="" type="checkbox"/> A <input type="checkbox"/> B <input type="checkbox"/> C <input type="checkbox"/> D
VCP of the rear	4 points	C	<input checked="" type="checkbox"/> A <input type="checkbox"/> B <input type="checkbox"/> C <input type="checkbox"/> D
VCP of the left	4 points	C	<input checked="" type="checkbox"/> A <input type="checkbox"/> B <input type="checkbox"/> C <input type="checkbox"/> D
VCP of the right	4 points	C	<input checked="" type="checkbox"/> A <input type="checkbox"/> B <input type="checkbox"/> C <input type="checkbox"/> D

Remark: Discharge should be considered on Contact and Air and Horizontal Coupling Plane (HCP) and Vertical Coupling Plane (VCP).

7. RF Field Strength Susceptibility Test

7.1. Test Standard and Level

Test Standard:	EN 61326-1 (IEC 61000-4-3)
Required Performance:	A
Frequency Range:	80MHz to 1000MHz/ 1.4GHz to 2.0GHz/ 2.0GHz to 2.7GHz
Field Strength:	10 V/m, 3V/m, 1V/m
Modulation:	1kHz Sine Wave, 80%, AM Modulation
Frequency Step:	1 % of preceding frequency value
Polarity of Antenna:	Horizontal and Vertical
Test Distance:	3 m
Antenna Height:	1.5 m
Dwell Time:	at least 0.5s

Test Level

Level	Field Strength V/m
1.	1
2.	3
3.	10
X.	Special

7.2. Test Setup

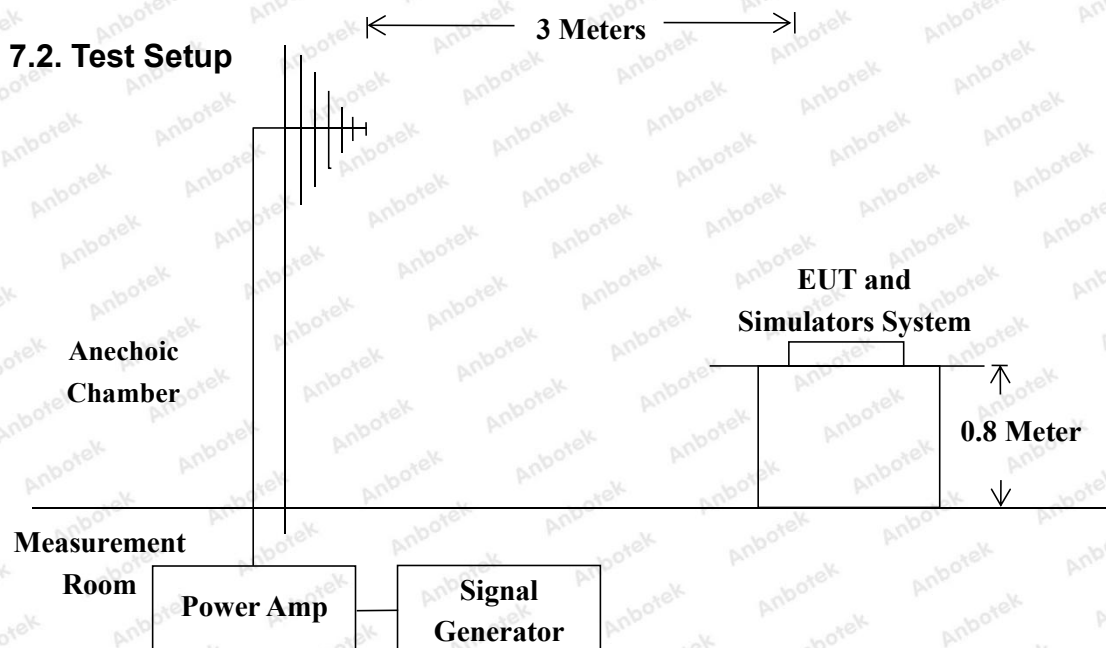

7.3. EUT Configuration on Measurement

The following equipments are installed on RF Field Strength susceptibility Measurement to meet EN 61326-1 requirements and operating in a manner which tends to maximize its emission characteristics in a normal application.

7.4. Operating Condition of EUT

7.4.1. Setup the EUT as shown on Section 7.2.

7.4.2. Turn on the power of all equipments.

7.4.3. After that, let the EUT work in test mode measure it.

7.5. Test Procedure

The EUT and support equipment, which are placed on a table that is 0.8 meter above ground and the testing was performed in a fully-anechoic chamber. The testing distance from antenna to the EUT was 3 meters.

- 1) 80 MHz to 1000 MHz the field strength level was 10V/m, 1.4 GHz to 2.0 GHz the field strength level was 3V/m, 2.0 GHz to 2.7 GHz the field strength level was 1V/m.
- 2) The frequency range is swept from 80 MHz to 1000 MHz, 1.4 GHz to 2.0 GHz, 2.0 GHz to 2.7 GHz with the signal 80% amplitude modulated with a 1kHz sine wave.
- 3) The dwell time at each frequency shall be not less than the time necessary for the EUT to be able to respond, but shall in no case be less than 0.5s.
- 4) The test was performed with the EUT exposed to both vertically and horizontally polarized fields on each of the four sides.

7.6. Measuring Results

PASS

Please refer to the following page.



RF Field Strength Susceptibility Test Results

Field Strength :	10 V/m, 3V/m, 1V/m	Temperature :	23.1°C
Expert conclusion :	A	Humidity :	50%
Power Supply :	AC 230V, 50Hz	Test Result :	<input checked="" type="checkbox"/> Pass <input type="checkbox"/> Fail
Dwell Time:	1s		

Frequency Range	Antenna Polarity	R.F. Field Strength	Azimuth	Result
80MHz~1000MHz	H / V	10 V/m (rms)	Front	<input checked="" type="checkbox"/> A <input type="checkbox"/> B <input type="checkbox"/> C <input type="checkbox"/> D
			Rear	
			Left	
			Right	
1.4GHz~2.0GHz	H / V	3 V/m (rms)	Front	<input checked="" type="checkbox"/> A <input type="checkbox"/> B <input type="checkbox"/> C <input type="checkbox"/> D
			Rear	
			Left	
			Right	
2.0GHz~2.7GHz	H / V	1 V/m (rms)	Front	<input checked="" type="checkbox"/> A <input type="checkbox"/> B <input type="checkbox"/> C <input type="checkbox"/> D
			Rear	
			Left	
			Right	

8. Electrical Fast Transient/Burst Immunity Test

8.1. Test Standard and Level

Test Standard:	EN 61326-1 (IEC 61000-4-4)
Performance criterion:	B
Severity Level 3: 2.00kV	

Test Level

Open Circuit Output Test Voltage $\pm 10\%$		
Level	On Power Supply Lines	On I/O (Input/Output) Signal data and control lines
1.	0.50 kV	0.25 kV
2.	1.00 kV	0.50 kV
3.	2.00 kV	1.00 kV
4.	4.00 kV	2.00 kV
X.	Special	Special

8.2. Test Setup

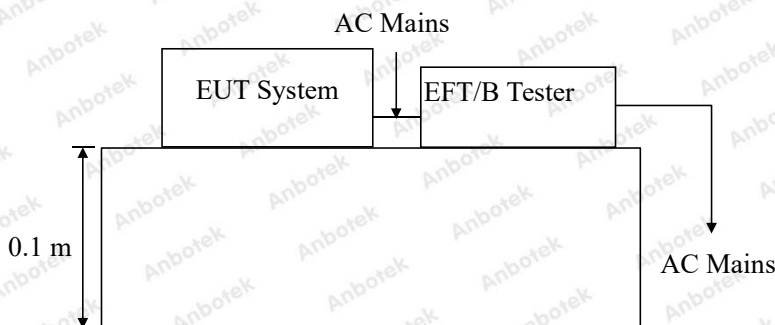

8.3. EUT Configuration on Measurement

The following equipments are installed on Electrical Fast Transient/Burst Immunity Measurement to meet EN 61326-1 requirements and operating in a manner which tends to maximize its emission characteristics in a normal application.

8.4. Operating Condition of EUT

- 8.4.1. Setup the EUT as shown in Section 8.2.
- 8.4.2. Turn on the power of all equipments.
- 8.4.3. Let the EUT work in test mode and measure it.

8.5. Test Procedure

The EUT is put on the table which is 0.1 meter high above the ground. This reference ground plane shall project beyond the EUT by at least 0.1m on all sides and the minimum distance between EUT and all other conductive structure, except the ground plane beneath the EUT, shall be more than 0.5m.

8.5.1. For input and output AC power ports:

The EUT is connected to the power mains by using a coupling device which couples the EFT interference signal to AC power lines. Both polarities of the test voltage should be applied during compliance test and the duration of the test is 2 mins.

8.5.2. For signal lines and control lines ports:

Select tests based on product characteristics.

8.5.3. For DC output line ports:

Select tests based on product characteristics.

8.6. Test Results

PASS

Please refer to the following page.



Electrical Fast Transient/Burst Test Results

Ambient Condition : 23.1°C / 50% RH		Expert conclusion : A	
Power Supply : AC 230V, 50Hz		Test Result : <input checked="" type="checkbox"/> Pass <input type="checkbox"/> Fail	
Inject Line : AC Mains		Inject Method: Direct	Inject Time(s): 120
Line	Polarity	Test Voltage (kV)	Result
AC Line	±	2.00kV	<input checked="" type="checkbox"/> A <input type="checkbox"/> B <input type="checkbox"/> C <input type="checkbox"/> D
DC Line			
Signal Line			

9. Surge Immunity Test

9.1. Test Standard and Level

Test Standard:	EN 61326-1 (IEC 61000-4-5)
Performance criterion:	B
Severity Level: Level 2, Line to Line: 1.0kV	

Test Level

Severity Level	Open-Circuit Test Voltage (kV)
1.	0.5
2.	1.0
3.	2.0
4.	4.0
X.	Special

9.2. Test Setup

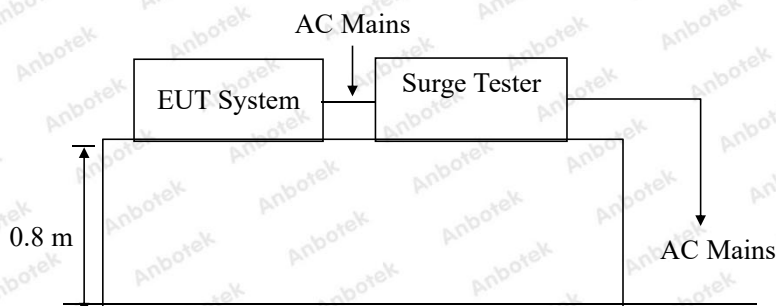

9.3. EUT Configuration on Measurement

The following equipments are installed on Surge immunity Measurement to meet EN 61326-1 requirements and operating in a manner which tends to maximize its emission characteristics in a normal application.

9.4. Operating Condition of EUT

- 9.4.1. Setup the EUT as shown in Section 9.2.
- 9.4.2. Turn on the power of all equipments.
- 9.4.3. Let the EUT work in test mode and measure it.

9.5. Test Procedure

9.5.1. Set up the EUT and test generator as shown on Section 9.2.

9.5.2. For line to line coupling mode, provide a 1.0 kV 1.2/50us voltage surge (at open-circuit condition) and 8/20us current surge to EUT selected points.

9.5.3. At least 5 positive and 5 negative (polarity) tests with a maximum 1/min repetition rate are conducted during test.

9.5.4. Different phase angles are done individually.

9.5.5. Record the EUT operating situation during compliance test and decide the EUT immunity criterion for above each test.

9.6. Test Results

PASS

Please refer to the following page.



Surge Immunity Test Results

Humidity :	50%			Temperature :	23.1℃
Power Supply :	AC 230V, 50Hz			Expert conclusion:	A
Test Result :	<input checked="" type="checkbox"/> Pass <input type="checkbox"/> Fail				
Location	Polarity	Phase Angle	Number of Pulse	Pulse Voltage (kV)	Result
L-N	±	<input checked="" type="checkbox"/> 0° <input checked="" type="checkbox"/> 90° <input checked="" type="checkbox"/> 180° <input checked="" type="checkbox"/> 270°	5	1.0 kV	<input checked="" type="checkbox"/> A <input type="checkbox"/> B <input type="checkbox"/> C <input type="checkbox"/> D
L-GND					
N-GND					

10. Injected Currents Susceptibility Test

10.1. Test Standard and Level

Test Standard	EN 61326-1 (IEC 61000-4-6)
Performance criterion	A
Severity Level 2: 3V (rms), (0.15MHz ~80MHz)	

Test Level

Level	Field Strength V
1.	1
2.	3
3.	10
X.	Special

10.2. Test Setup

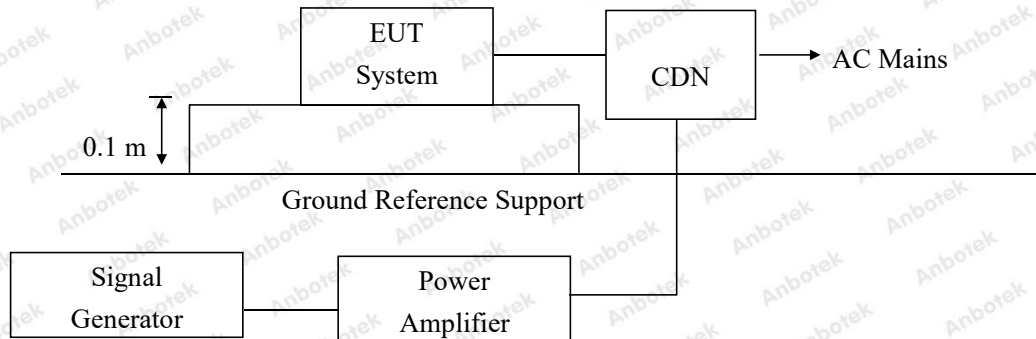

10.3. EUT Configuration

The following equipments are installed on currents susceptibility Measurement to meet EN 61326-1 requirements and operating in a manner which tends to maximize its emission characteristics in a normal application.

10.4. Operating Condition of EUT

- 10.4.1. Setup the EUT as shown in Section 10.2.
- 10.4.2. Turn on the power of all equipments.
- 10.4.3. Let the EUT work in test mode and measure it.

10.5. Test Procedure

- 1) Set up the EUT, CDN and test generators as shown on Section 10.2.
- 2) Let the EUT work in test mode and measure it.
- 3) The EUT are placed on an insulating support 0.1m high above a ground reference plane. CDN (coupling and decoupling device) is placed on the ground plane about 0.3m from EUT. Cables between CDN and EUT are as short as possible, and their height above the ground reference plane shall be between 30 and 50 mm (where possible).
- 4) The disturbance signal described below is injected to EUT through CDN.
- 5) The EUT operates within its operational mode(s) under intended climatic conditions after power on.
- 6) The frequency range is swept from 150KHz to 80MHz using 3V signal level, and with the disturbance signal 80% amplitude modulated with a 1KHz sine wave.
- 7) The rate of sweep shall not exceed $1.5 \cdot 10^{-3}$ decades/s. Where the frequency is swept incrementally, the step size shall not exceed 1% of the start and thereafter 1% of the preceding frequency value.
- 8) Recording the EUT operating situation during compliance testing and decide the EUT immunity criterion.

10.6. Test Results

PASS

Please refer to the following page.



Injected Currents Susceptibility Test Results

Humidity : 50%		Temperature : 23.1℃	
Power Supply : AC 230V, 50Hz		Expert conclusion: A	
Test Result : <input checked="" type="checkbox"/> Pass <input type="checkbox"/> Fail			
Frequency Range (MHz)	Injected Position	Strength (Unmodulated)	Result
0.15 ~ 80	AC Mains	3V	<input checked="" type="checkbox"/> A <input type="checkbox"/> B <input type="checkbox"/> C <input type="checkbox"/> D
<p>Remark : 1. Modulation Signal:1KHz 80% AM</p>			

11. MAGNETIC FIELD SUSCEPTIBILITY TEST

11.1. Test Standard and Level

Test Standard	EN 61326-1 (IEC 61000-4-8)
Performance Criterion	A
Severity Level: Level 4, 30A / m	

Test Level

Level	Field Strength A/m
1.	1
2.	3
3.	10
4.	30
5.	100
X.	Special

11.2. Test Setup

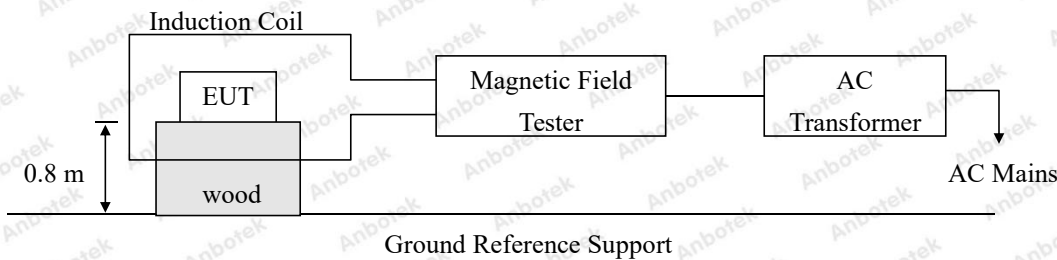

11.3. EUT Configuration on Test

The following equipments are installed on Magnetic Field Susceptibility Measurement to meet EN 61326-1 requirements and operating in a manner which tends to maximize its emission characteristics in a normal application.

11.4. Operating Condition of EUT

- 11.4.1. Setup the EUT as shown in Section 11.2.
- 11.4.2. Turn on the power of all equipments.
- 11.4.3. Let the EUT work in test mode and measure it.

11.5. Test Procedure

The EUT is placed in the middle of a induction coil (1*1m), under which is a 1*1*0.1m (high)table, this small table is also placed on a larger table, 0.8 m above the ground. Both horizontal and vertical polarization of the induction coil are set on test, so that each side of the EUT is affected by the magnetic field. Also can reach the same aim by change the position of the EUT.

11.6. Test Results

PASS

Please refer to the following page.



Magnetic Field Immunity Test Results

Temperature: 23.1°C		Humidity: 50%	
Power Supply : AC 230V, 50Hz		Expert conclusion : A	
Test Result : <input checked="" type="checkbox"/> Pass <input type="checkbox"/> Fail			
Test Level (A/M)	Testing Duration	Coil Orientation	Result
30	5 mins	X	<input checked="" type="checkbox"/> A <input type="checkbox"/> B <input type="checkbox"/> C <input type="checkbox"/> D
30	5 mins	Y	<input checked="" type="checkbox"/> A <input type="checkbox"/> B <input type="checkbox"/> C <input type="checkbox"/> D
30	5 mins	Z	<input checked="" type="checkbox"/> A <input type="checkbox"/> B <input type="checkbox"/> C <input type="checkbox"/> D
Test Level (A/M)	Testing Duration	Coil Orientation	Result

12. Voltage Dips And Interruptions Test

12.1. Test Standard and Level

Test Standard:	EN 61326-1 (IEC 61000-4-11)
Performance Criterion:	B&C

Test Level		
Test Level %UT	Voltage dip and short interruptions %UT	Duration (in period)
0	100	0.5
40	60	1
70	30	5
0	100	10
		25
		50
		*

12.2. Test Setup

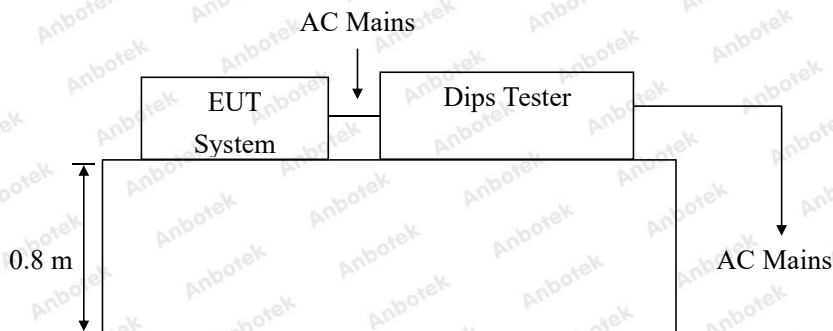

12.3. EUT Configuration on Measurement

The following equipments are installed on Voltage dips and interruptions Measurement to meet EN 61326-1 requirements and operating in a manner which tends to maximize its emission characteristics in a normal application.

12.4. Operating Condition of EUT

- 12.4.1. Setup the EUT as shown in Section 12.2.
- 12.4.2. Turn on the power of all equipments.
- 12.4.3. Let the EUT work in test mode and measure it.

12.5. Test Procedure

- 1) Set up the EUT and test generator as shown on Section 12.2.
- 2) The interruptions is introduced at selected phase angles with specified duration.
- 3) Record any degradation of performance.

12.6. Test Results

PASS

Please refer to the following page.



Voltage Dips and Interruptions Test Results

Temperature : 23.1℃		Humidity : 50%	
Power Supply : AC 230V, 50Hz		Expert conclusion : B&C	
Test Result : <input checked="" type="checkbox"/> Pass <input type="checkbox"/> Fail			
Test Level % UT	Voltage Dips & Short Interruptions % UT	Duration (in periods)	Result
0	100	1P	<input type="checkbox"/> A <input checked="" type="checkbox"/> B <input type="checkbox"/> C <input type="checkbox"/> D
40	60	10P	<input type="checkbox"/> A <input type="checkbox"/> B <input checked="" type="checkbox"/> C <input type="checkbox"/> D
70	30	25P	<input type="checkbox"/> A <input type="checkbox"/> B <input checked="" type="checkbox"/> C <input type="checkbox"/> D
0	100	250P	<input type="checkbox"/> A <input type="checkbox"/> B <input checked="" type="checkbox"/> C <input type="checkbox"/> D
Test Level % UT	Voltage Dips & Short Interruptions % UT	Duration (in periods)	Result

APPENDIX I -- TEST SETUP PHOTOGRAPH

Photo of Power Line Conducted Emission Test



Photo of Radiated Emission Test



Photo of Flicker/ Harmonic Test



Photo of Electrostatic Discharge Immunity Test



Photo of RF Field Strength susceptibility Test



Photo of Electrical Fast Transient/Burst Immunity Test



Photo of Surge Immunity Test



Photo of Injected currents susceptibility Test

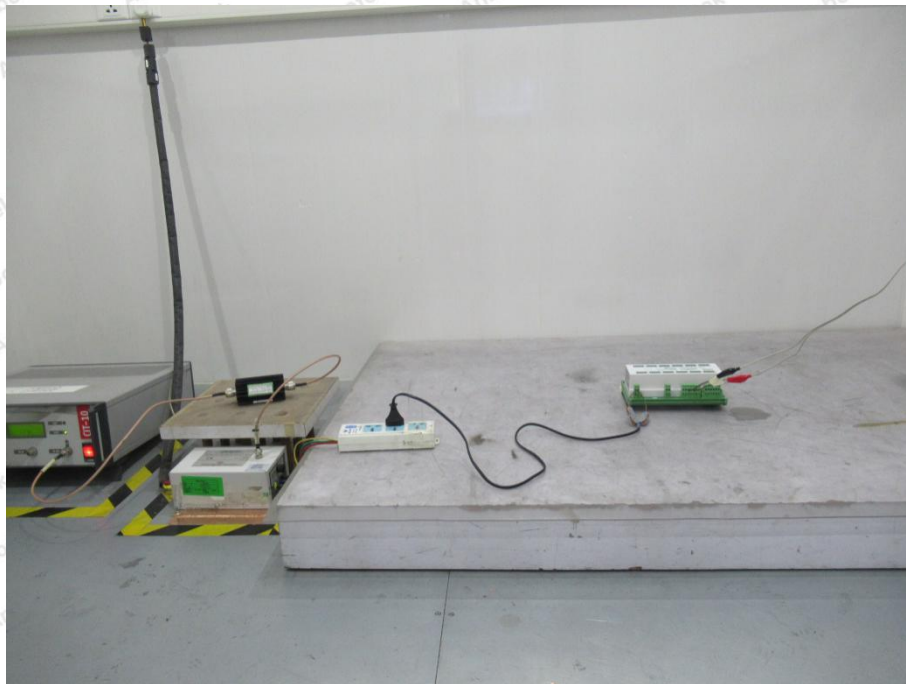

Photo of Magnetic Field Susceptibility Test

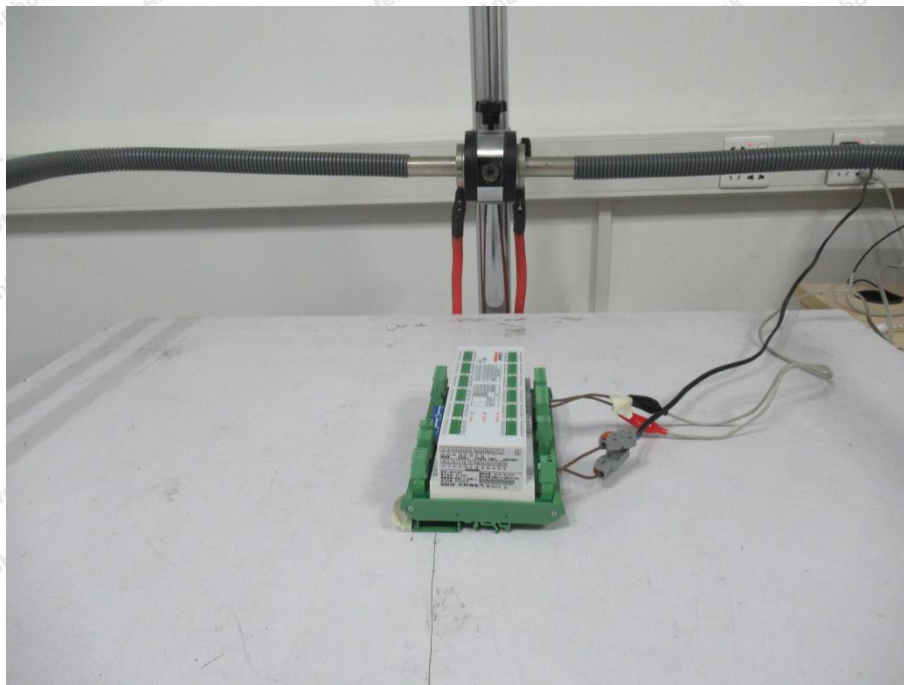
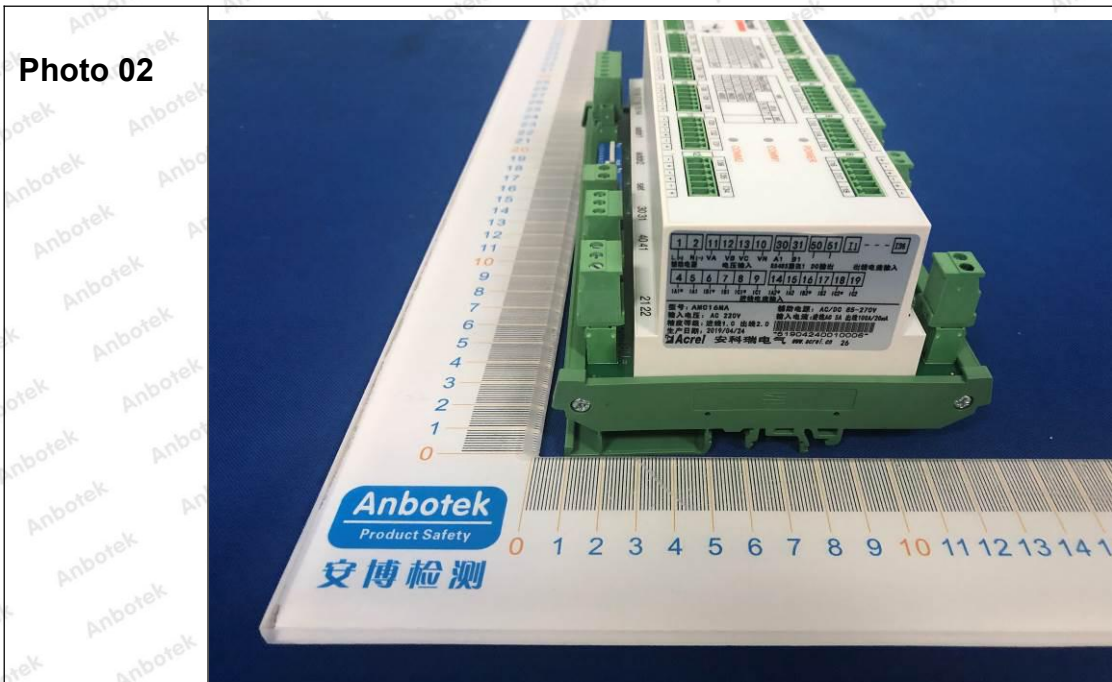
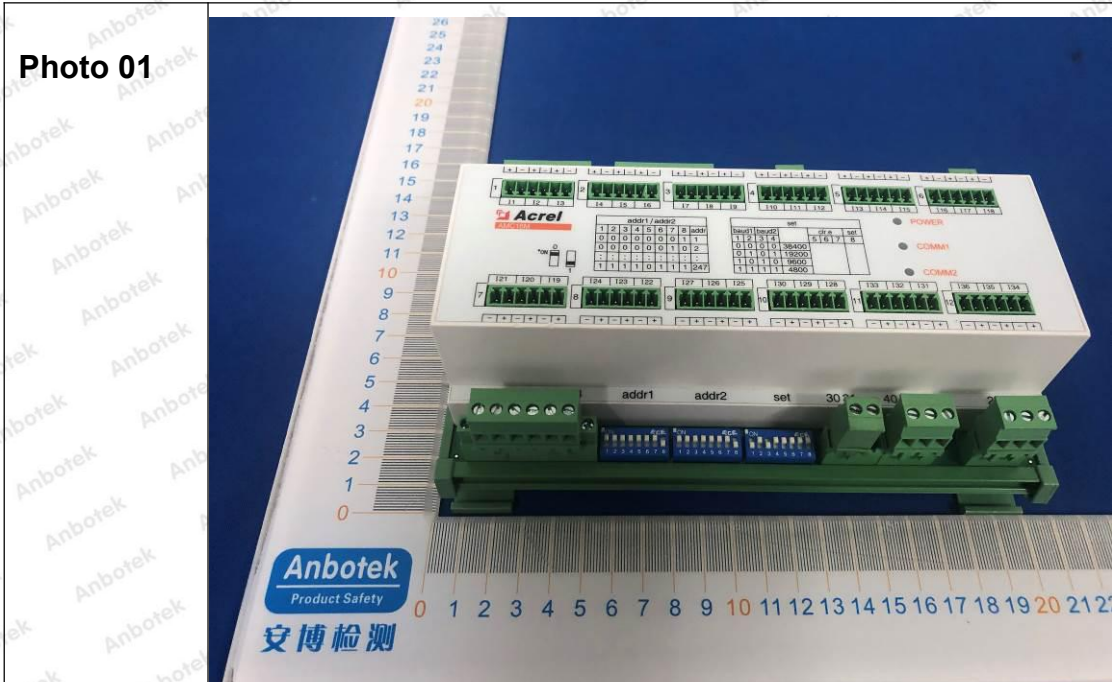

Photo of Voltage Dips and Interruptions Test



APPENDIX II -- Photo Documentation



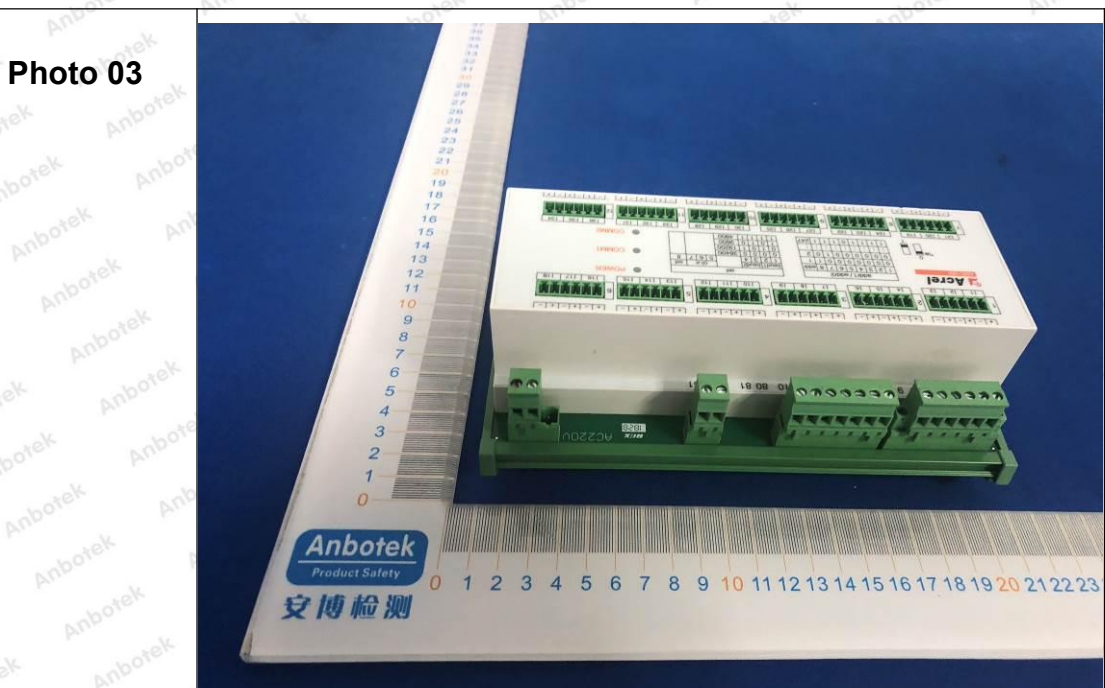

Photo 05

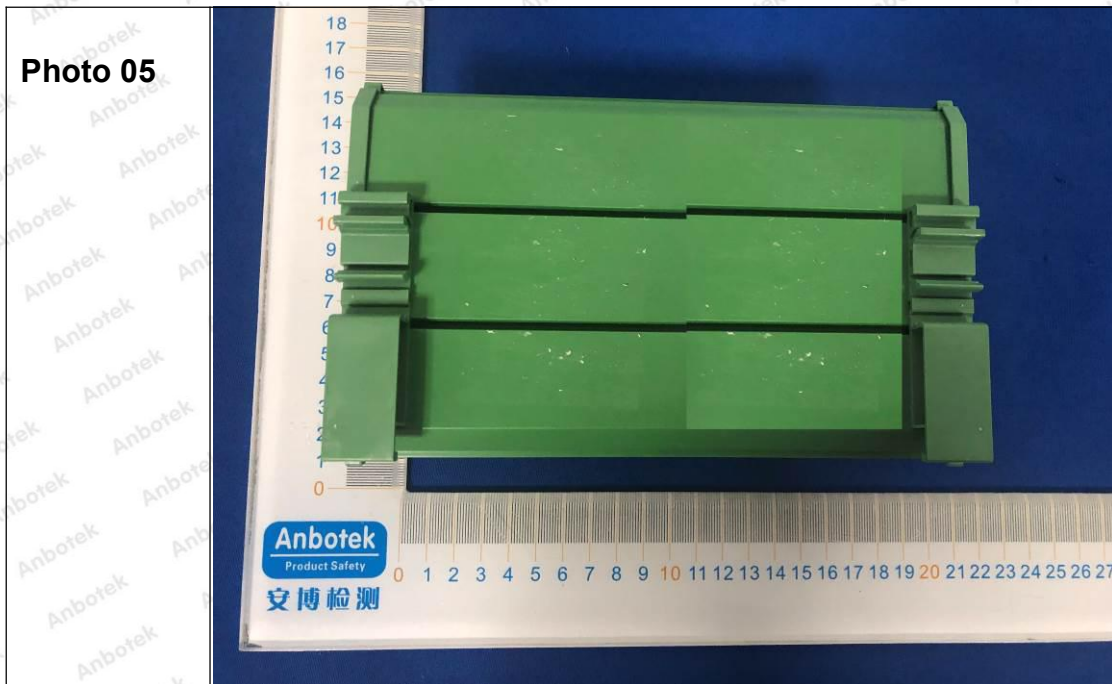

Photo 06

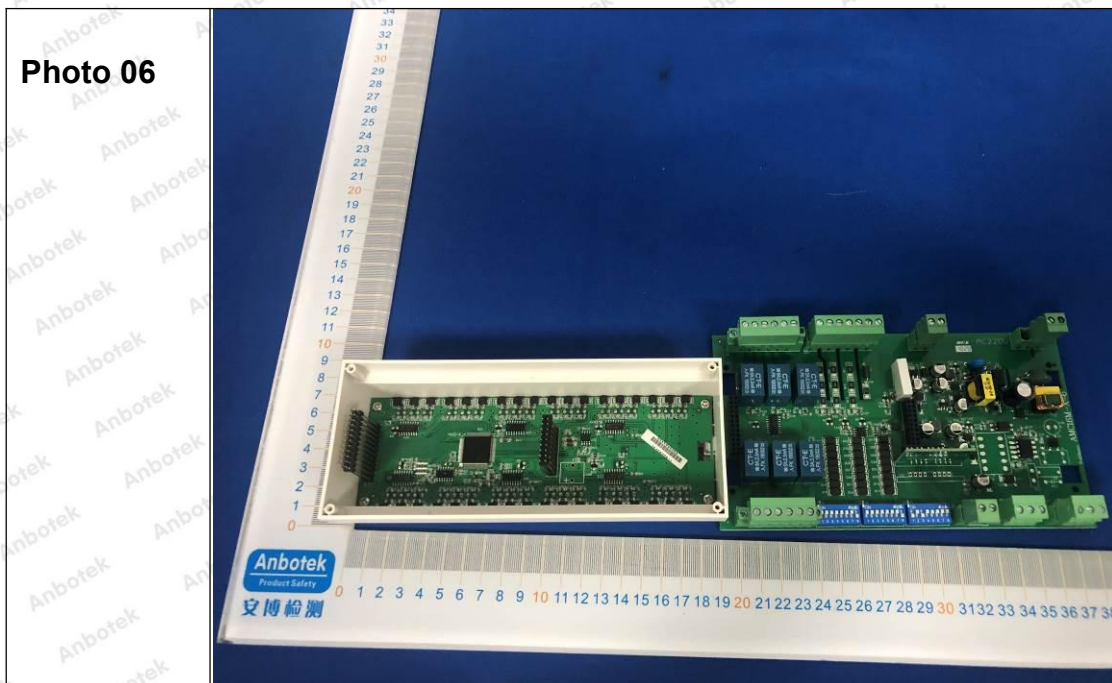

Photo 07

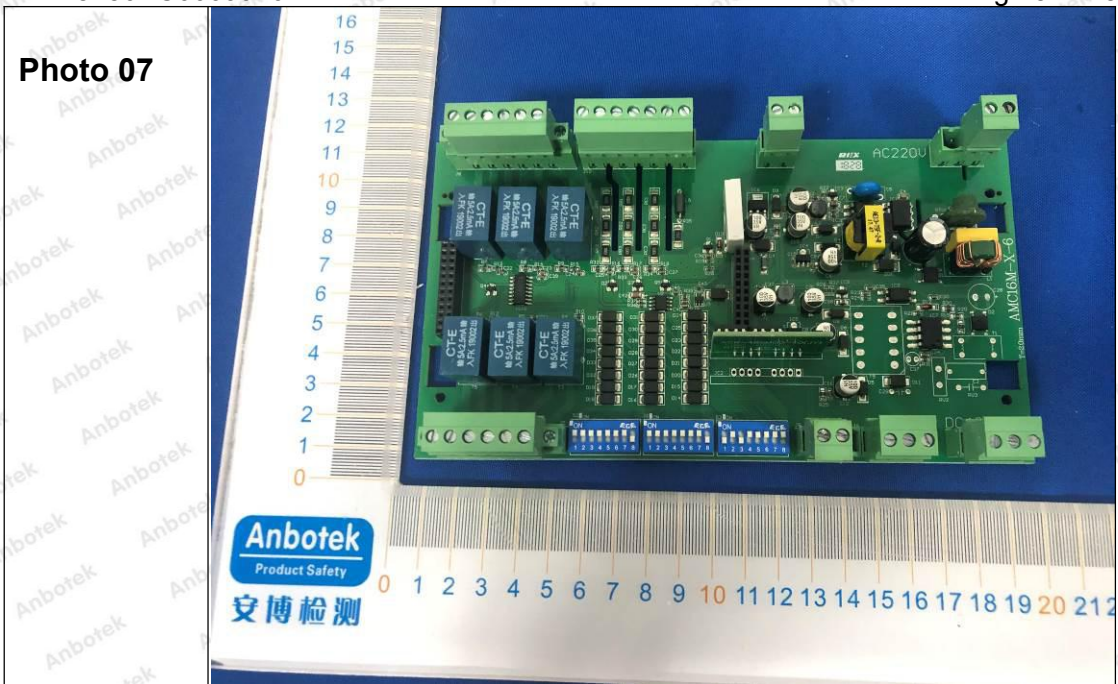

Photo 08

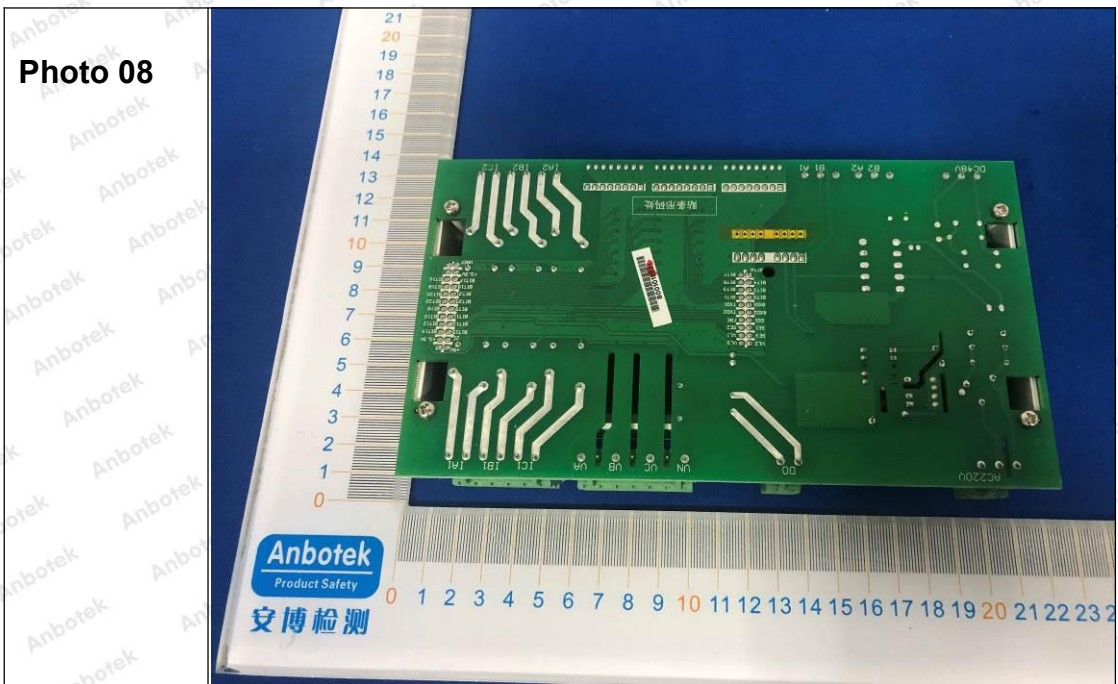
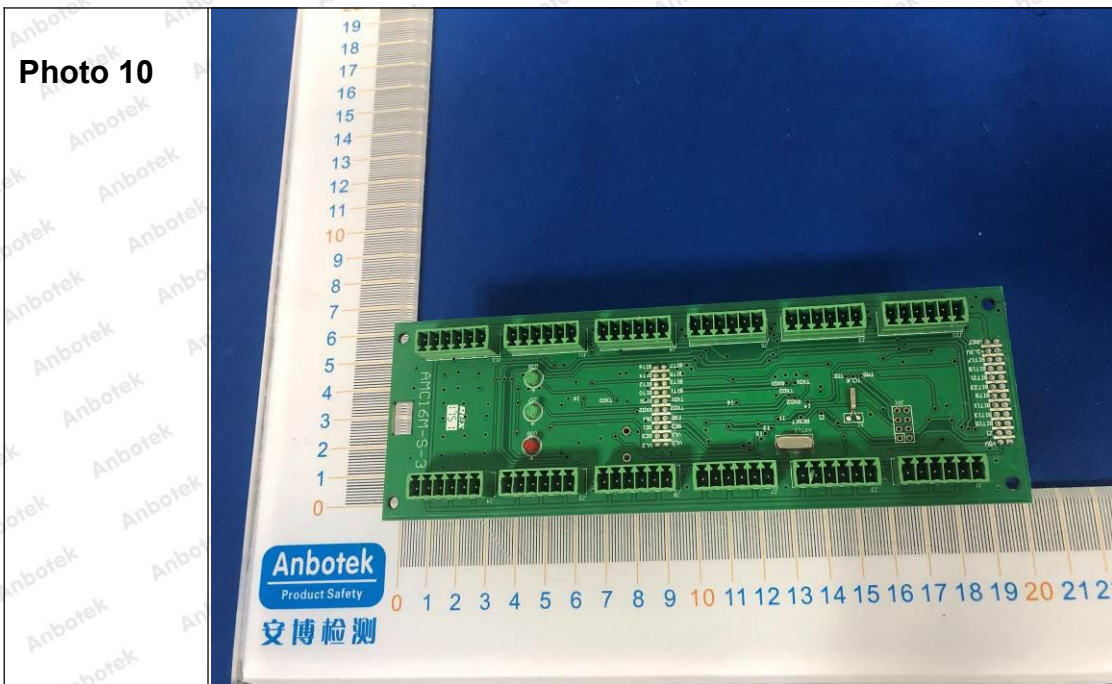

Photo 09



Photo 10



CE Label

1. The CE conformity marking must consist of the initials 'CE' taking the following form:

If the CE marking is reduced or enlarged, the proportions given in the above graduated drawing must be respected.

2. The CE marking must have a height of at least 5 mm except where this is not possible on account of the nature of the apparatus.

3. The CE marking must be affixed to the product or to its data plate. Additionally it must be affixed to the packaging, if any, and to the accompanying documents.

4. The CE marking must be affixed visibly, legibly and indelibly.

It must have the same height as the initials 'CE'.

----- End of Report -----

